

SAFETY FIRST! In all cases, follow jobsite safety plans, and consider your own personal safety. Make sure you are wearing PPE, and are securely positioned so that you will not slip or fall during installation.

This procedure is for the installation of assembled #18 HRC 500 Ultimate Positional Couplers and steel reinforcing bars.

The male and female components are screwed together hand-tight without the need to rotate the bar themselves. (See Figure 1). The assembly must then be hand-tightened to a snug fit and then **torqued to 200 lb-ft**. Lubricate threads and use wrenches as necessary. Visual inspection must be performed according to Figure 2. More than one full thread must not be visible. The male couplers & female sleeve must not touch or bottom out.

If the upset heads are not formed correctly, threads will be visible, or the coupler components will touch or bottom out before the bars are tightened.

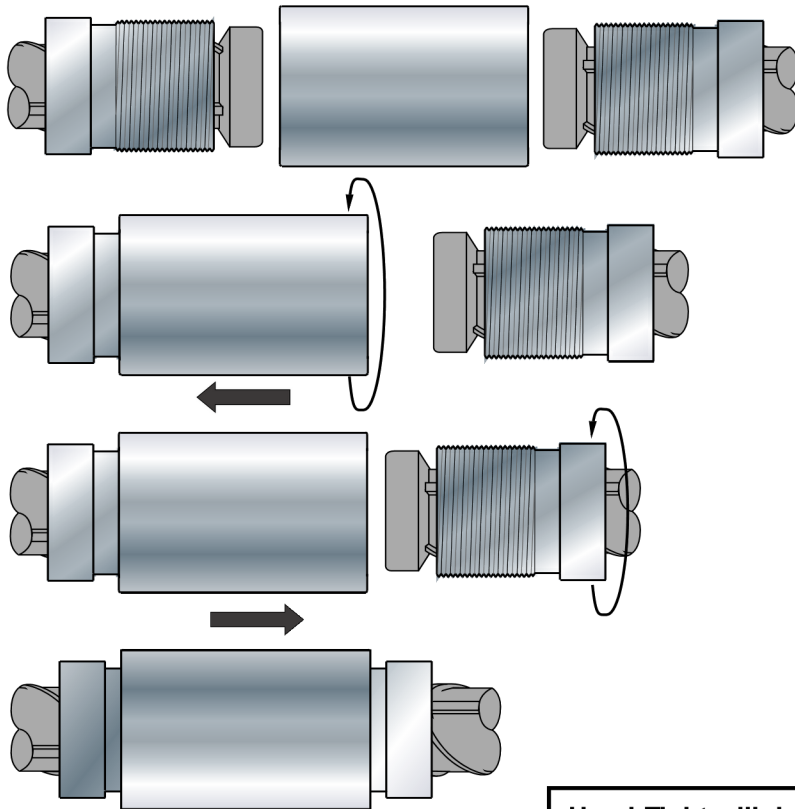
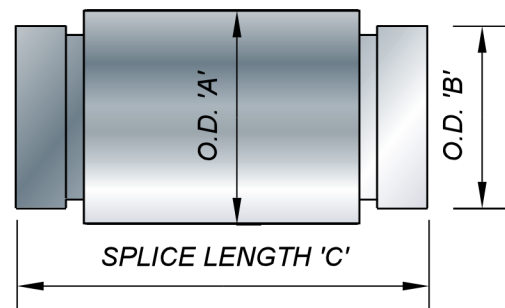

Figure 1

Dimensions	in
A. Coupler Sleeve O.D.	4 1/4
B. Male Coupler O.D.	3 5/8
C. Coupler Length (min)	7 7/8*
(max)	8 3/4**

* To ensure snug fit and sufficient head thickness.
 ** One full thread showing each end.
 Transition to smaller bar size available.



Hand-Tight will develop full thread tensile capacity, but pipe wrenches may be required to fully tighten and eliminate movement within the coupler.

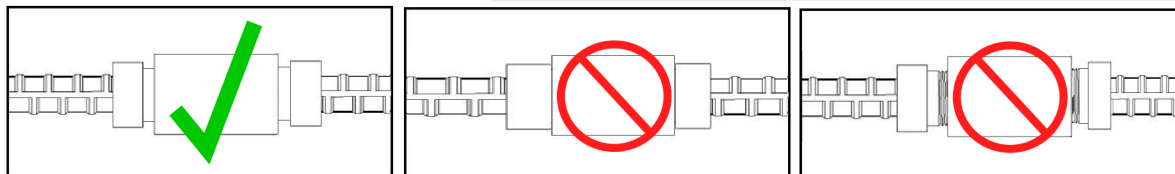

Figure 2 – #18 500 Series Visual Inspection