

#18 HRC 500 SERIES ULTIMATE POSITIONAL COUPLER

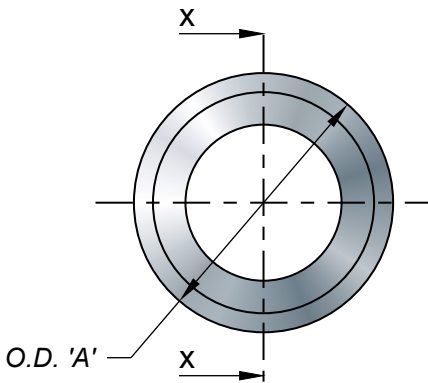

Designed to meet Caltrans Ultimate (A706-60) and IBC Type 2 (A706-60/80)*



END VIEW

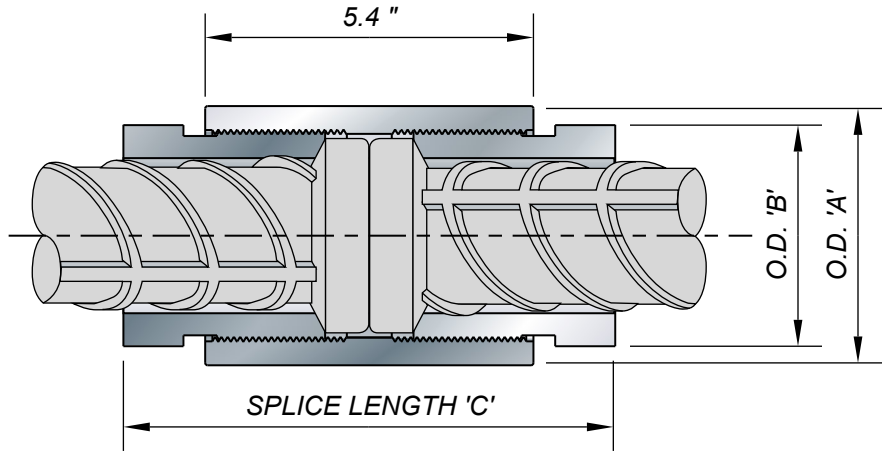

SECTION ALONG X-X

#18 Rebar	A615/A706-60	A706-80	Dimensions	in	mm
Min Yield [lbs]	240,000	320,000	A. Coupler O.D.	4 1/4	108
Min Tensile [lbs]	320,000	400,000	B. Male Coupler O.D.	3 5/8	92
Torque: Hand tighten to snug fit			C. Coupler Length (min)	7 7/8*	200*
Lubricate threads and use pipe wrench if necessary.			(max)	8 3/4**	222**

Transition to smaller bar size available.

* To ensure snug fit and sufficient head thickness.

** One full thread showing each end.

Caltrans prequalification & ICC-ES evaluation pending

All data subject to change without notice.

Rev. 20-0130



HEADED REINFORCEMENT CORP.

11200 Condor Avenue • Fountain Valley, CA. 92708, USA

Tel: 714-557-1455 • FAX: 714-557-4460 • www.HRC-USA.com