

HRC® 551 Series
#18 Anchor T-Heads

Installation Procedure

SAFETY FIRST! In all cases, follow jobsite safety plans, and consider your own personal safety. Make sure you are wearing PPE, and are securely positioned so that you will not slip or fall during installation.

This procedure is for the installation of assembled HRC 551 Anchor T-Heads and steel reinforcing bars.

The male and female components are screwed together hand-tight around the upset head without the need to rotate the bar themselves (see Figure 1). The assembly must then be hand-tightened to a snug fit. Lubricate threads with grease or WD 40 and use wrenches if necessary. Full threads must not be visible.

Full threads must not be visible.

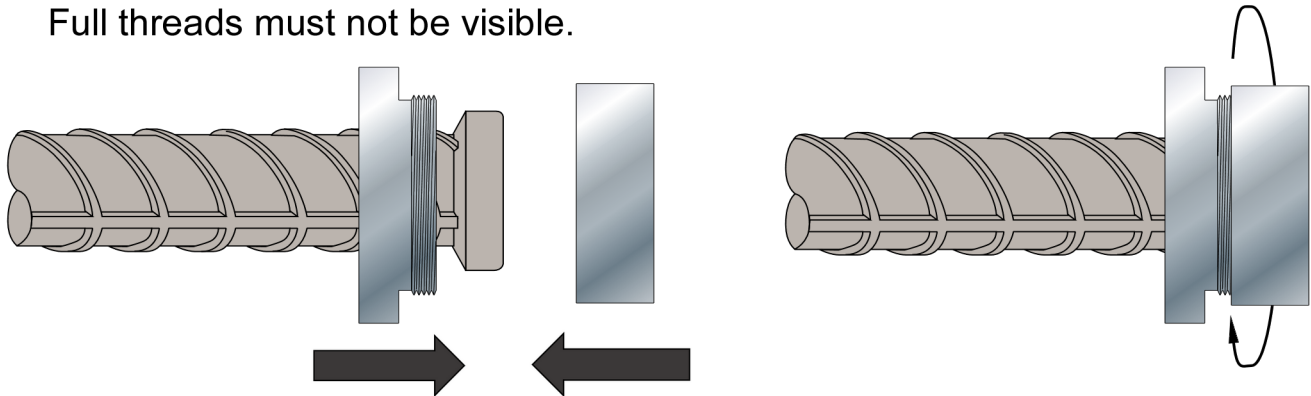
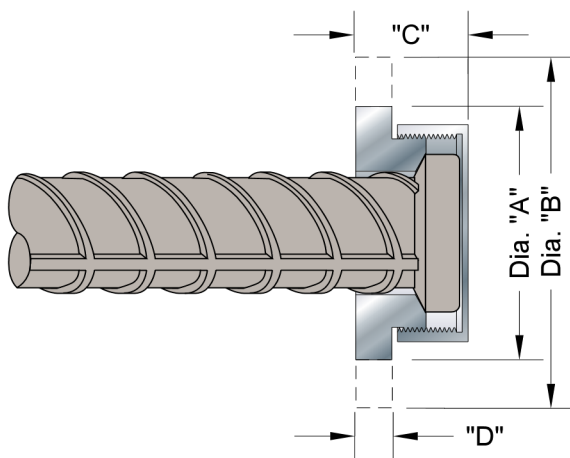

Figure 1 – 551 Series Anchor T-Heads



#18 Dimensions	inch
A. HRC 551H (4Ab) O.D.	5.25
B. HRC 551L (9Ab) O.D.	7.25
C. Assembled Thickness (typ)	2.17*
D. Thickness (min)	0.79

* Tolerance +/- 0.16" (4mm)

#18 HRC 551H

4Ab Bearing Area

#18 HRC 551L

9Ab Bearing Area

CALIFORNIA PROP. 65 WARNING



CANCER AND REPRODUCTIVE HARM
 WWW.P65WARNINGS.CA.GOV

